

# Commercial Refrigerant PLUS-8 (rev B) Recovery System

## Operation Manual



**TO BE OPERATED BY QUALIFIED PERSONNEL ONLY**

<u>Table of Contents</u>	<u>page</u>
Specifications.....	2
Introduction.....	3
General Safety Instructions.....	4
Direct Liquid or Vapor Recovery Operation.....	5
Liquid Push-Pull Operation.....	6
Routine Maintenance.....	7

# Specifications



## PLUS-8 Specifications

Compressor Type	1/2 HP Oil-less Reciprocating Compressor
Dimensions	20cm (8") wide x 37cm (14.5") long x 30.5cm (12") high
Weight	12 kg (28 lbs.)
Operating Range	0°C (32°F) to 49°C (120°)
Power Source	230 VAC 50Hz 1Ph
Power Consumption	750 W
Suction Pressure Gauge	-1 to 35 bar
Discharge Pressure Gauge	0 to 55 bar
Filtration	Cleanable 100-mesh screen integrated into Suction Port
Shut-off Valves	Both Suction and Discharge diaphragm manifold valves
Construction	Heavy gauge aluminum chassis with High Density Polyethylene Case
Overload Protection	6A thermal circuit breaker
High Pressure Shut-off	38 bar (550 psig)
Refrigerants	R-12, R-134a, R-401C, R-500, R-401A R-409A, R-401B, R-407D, R-22 R-502, R-407C, R-402B, R408A, R-509 R-407A, R-404A, R-402A, R-507, R-407B, R-410A
Control System	Dependable Electro-mechanical interlock system
Flow Rate	
Direct Vapor	Up to 28 kg/hr
Direct Liquid	Up to 59 kg/hr
Push-Pull Liquid	Up to 265 kg/hr

# Introduction

Thank you for purchasing the REFCO PLUS-8 series unit. REFCO is dedicated to give you the fastest and most reliable equipment to meet all your commercial refrigerant recovery requirements.

The PLUS-8 is designed for servicing commercial and residential refrigeration systems. Simply follow the quick start guide and turn it on. No need to watch for liquid refrigerant, this unit automatically handles it. Once the recovery is complete, simply turn the center valve to the SELF-CLEARING position. Now the unit is ready for the next type of refrigerant.

The REFCO PLUS-8 series utilizes a ½ hp (0.75kW) oil-less compressor, non-restrictive diaphragm manifold valves, and a liquid regulating valve to make it the first truly direct liquid or vapor refrigerant recovery unit.

The following are additional features:

- “On the Run” SELF-CLEARING valve. No need to turn off the unit when switching from recovery to self-clearing.
- On board SUCTION and DISCHARGE gauges.
- 0 to 55 bar (800-psig) discharge gauge to handle R410A.
- Small physical size.
- Weighs only 13.1 kg (29 lbs.)
- Integrated easy to use carrying handle.
- High Pressure manual reset button set at 38 bar.
- Easy and secure filter accesses. No dangling filters to be damaged.
- Replaceable or cleanable filter cartridge.
- The shut-off valves utilize fully ported Teflon valves. Easy to service if replacement required.
- Heavy-duty powder coated aluminum chassis surrounded by a tough High-Density Polyethylene case.
- Maintenance free Oil-less compressor

To help you get a good start, please continue to carefully read the balance of this manual. This manual contains important information on the proper procedures for operating this equipment. Please pay close attention to the safety information, WARNING and CAUTIONS provided throughout this manual. Always remember “SAFETY FIRST”.

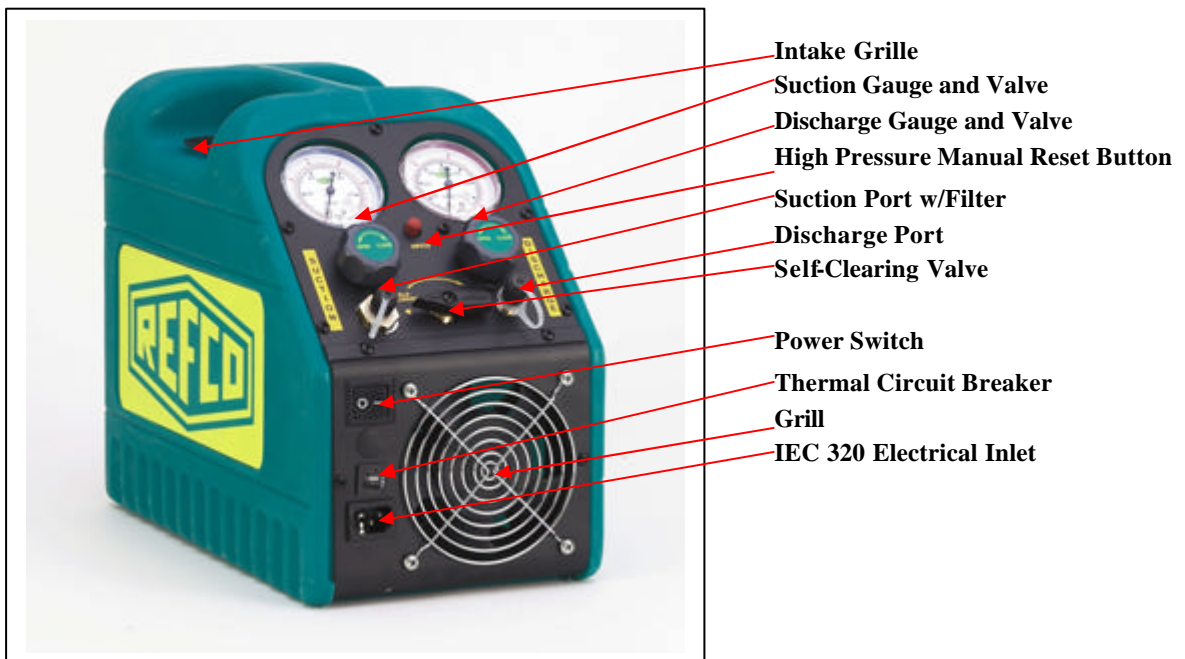

# General Safety Instructions

**ONLY QUALIFIED SERVICE PERSONNEL SHOULD OPERATE THIS UNIT. MOST STATES, COUNTRIES, ETC... MAY REQUIRE THE USER TO BE LICENSED. PLEASE CHECK WITH YOUR LOCAL GOVERNMENT AGENCY.**

**Danger-** the recovery tank used with this contains liquid refrigerant. Overfilling of the recovery tank may cause a violent explosion resulting in severe injury or even death.

**As a minimum, please use a scale to continuously monitor the recovery tank weight.**

**Danger-** Avoid breathing refrigerant vapors and lubricant vapor or mist. Breathing high concentration levels may cause heart arrhythmia, loss of consciousness, or even cause suffocation.

**Danger- ELECTRICAL SHOCK HAZARD-** Always disconnect power source when servicing this equipment.

**Danger- EXPLOSION RISK.** Do not recover flammable refrigerants

**Caution-** all hoses may contain liquid refrigerant under pressure. Contact with refrigerant may cause frostbite or other related injuries. Wear proper personal protective equipment such as safety goggles and gloves. When disconnecting any hose, please use extreme caution.

**Caution-** avoid breathing refrigerant vapors and/or lubricant mist. Exposure may irritate eyes, nose, throat, and skin. Please read the manufacturers Material Safety Data Sheet for further safety information on refrigerants and lubricants.

**Caution-** to reduce the risk of fire, avoid the use of extension cords thinner than NO. 14 awg. (1,5mm<sup>2</sup>) to prevent the overheating of this cord please keep length to a minimum.

**Caution-** do not use this equipment in the vicinity of spilled or open containers of gasoline or other flammable substances. Make certain that all safety devices are functioning properly before operating the equipment.

This equipment is intended for use of one refrigerant at a time until the Self-Clearing feature is used. Mixing of different refrigerants will cause your recovered supply of refrigerant to become contaminated. Note: It is very expensive to destroy mixed or damaged refrigerants.

# Operation Direct Vapor or Liquid Recovery



1. Connect the unit as shown in Diagram 1.  
*Note: The recovery tank must be rated for 38 bar.*
2. Open the vapor valve on the Recovery Tank.
3. Open **DISCHARGE** valve on PLUS-8.
4. Rotate the center valve to the **'RECOVERY'** position.
5. Push the Main Power Switch "ON".

If the unit fails to start, open the suction valve and rotate the center valve to the **'SELF-CLEARING'** position for 5-10 seconds. Then rotate back to the **'RECOVERY'** position. Reset circuit breaker. Push the **START** switch.

6. Once unit has started, open the **SUCTION** valve on the PLUS-8 to start the refrigerant flow.
7. Monitor the suction gauge until it falls below the required vacuum level. Close the **SUCTION** valve.
8. Rotate the center valve to the **SELF-CLEARING** position. Again monitor suction gauge. Once the gauge reads a vacuum, turn unit off.

**RECOVERY AND SELF-CLEARING ARE COMPLETE**

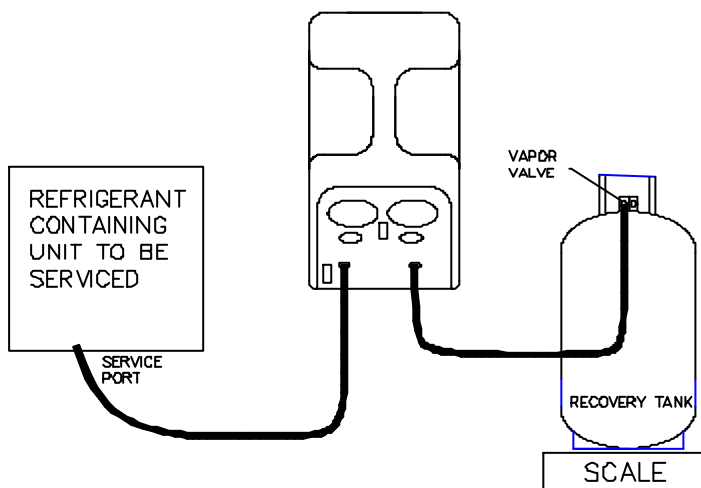
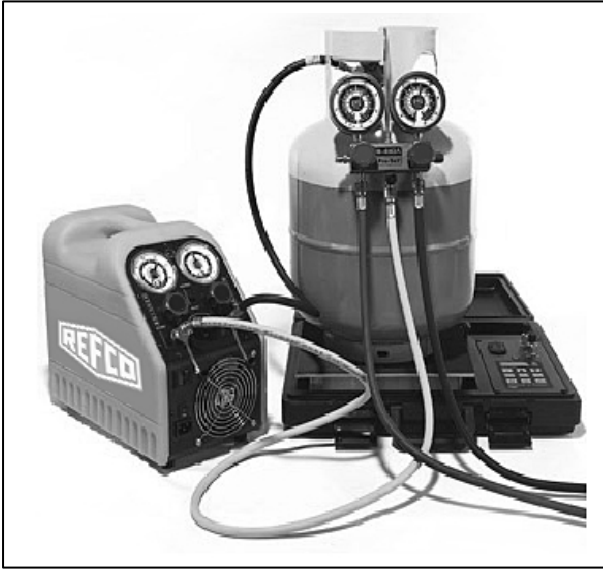

Diagram 1

# Operation Push-Pull Liquid Recovery



1. Connect the unit as shown in Diagram 2.  
*Note: The recovery tank must be rated for 38 bar.*
2. Open both valves on the Recovery Tank.
3. Open **DISCHARGE** valve on PLUS-8.
4. Rotate the center valve to the '**SELF-CLEARING**' position.
5. Push the **MAIN POWER SWITCH "ON"**.

If the unit fails to start, open the suction valve and rotate the center valve to the "**SELF-CLEARING**" position for 5-10 seconds. Then rotate back to the "**RECOVERY**" position. Reset circuit breaker. Push the **START** switch.

6. Once unit has started, open the **SUCTION** valve on the PLUS-8 to start the refrigerant flow.
7. Monitor the optional inline sight glass for liquid refrigerant movement.
8. Once liquid refrigerant is no longer present, close **SUCTION** valve. When the Suction gauge falls into a vacuum, proceed to Direct Vapor Recovery Operation. (prior page)

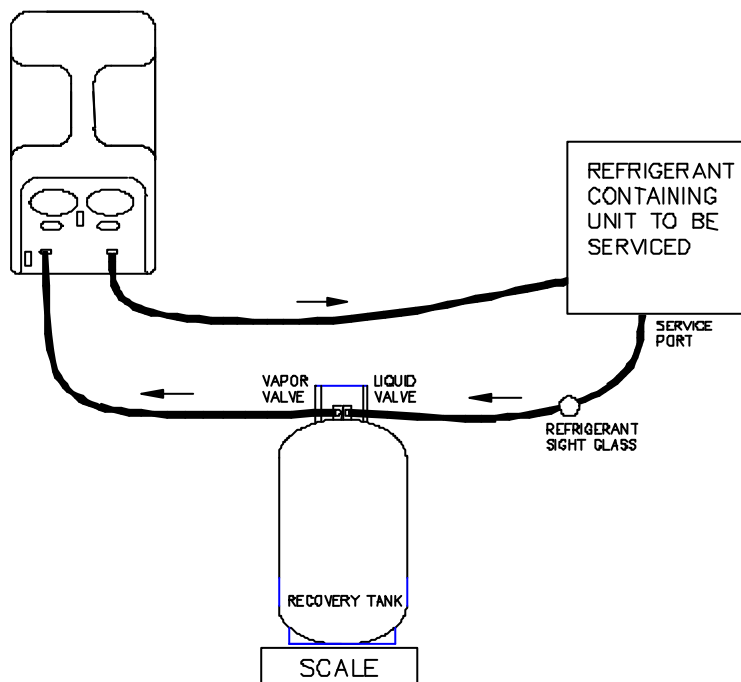

Diagram 2

## Routine Maintenance

**Filter Maintenance-** the PLUS-8 is equipped with a 100-mesh screen filter. This filter should be checked periodically. A partially clogged filter will slow down the recovery rate of this unit.

Replace the filter cartridge as follows:

1. Use a 7/8" socket or boxed end wrench to loosen the suction port as shown in Figure 1.
2. Once loose, remove the suction port- filter cartridge assembly is shown in Figure 2.
3. Either clean the current cartridge or replace with new cartridge.
4. Inspect O-ring. Re-lubricate with compressor oil or equivalent.
5. Place filter back into suction port fitting.
6. Hand tighten this assembly back onto the PLUS-8.
7. Use a 7/8" socket or boxed end wrench to tighten 1/8 of a turn. Do not over tighten, damage to the O-ring may occur.
8. Check the connection for leaks.



Figure 1



Figure 2

### Refrigeration Service Products and Components

**REFCO Manufacturing Ltd.**  
Industriestrasse 11  
CH-6285 Hitzkirch (Switzerland)

Telefon +41 (0) 41 919 72 82  
Telefax +41 (0) 41 919 72 83  
[info@REFCO.ch](mailto:info@REFCO.ch) [www.REFCO.ch](http://www.REFCO.ch)

